



INSTALLATION GUIDE

Before Installation

Moisture Considerations

It's important to keep moisture from penetrating and pooling behind siding, causing damage to the wood and affecting the factory-finish.

Flashing should be installed over all openings, flat surfaces, and where additional drainage is needed such as fascia.

Flashing and weather seal should be applied around windows, doors, and other openings.

Gutters and deflective flashing should be installed as needed.

Any moisture that finds its way between the siding and barrier needs to be able to escape. Strapping or Home Slicker should be installed in order for this to occur.

Ventilation Considerations

Heat and moisture need a way to escape from between the siding and building wrap. Most often, this is done with the use of furring and ventilation strips to create air gaps (also called rainscreens). There should also be a minimum of 1/2" open space at the bottom and top of walls to allow air to circulate.

- Starter Strips: Should be used around the perimeter of the building.
- L Strips: Should be used at the top of windows and the top and bottom of walls.
- J Strips: Should be installed at the bottom of windows and tops of walls.

Installing siding in a way that traps moisture and/or restricts ventilation can cause damage to the siding and factory-finish and will void any warranties.

Pre-Installation

Inspect the siding prior to installation. If the product is deemed to be defective for any reason including, but not limited to, colour defects, it should not be installed. The product should also be inspected for damage and, if found, should not be installed. Please notify The WoodSource immediately of any defects.

Keep factory-finished siding in a dry, well-ventilated place prior to installation. It should be stored at least 6" from the ground. Do not completely wrap the siding, as air circulation is required.

Cover unused siding with original packaging at all times, even during installation.

- All field cuts must be finished, even if they will not be visible. Touch-ups should be applied prior to installation.
- Please use the same factory-applied finish to coat any cuts made onsite.
- Refer to the maintenance guide for more information on how to properly apply finish.

Building Codes

Always meet or exceed local building code when installing your product.

Installation

Moisture Considerations

It's important to keep moisture from penetrating and pooling behind siding, causing damage to the wood and affecting the factory-finish.

Flashing should be installed over all openings, flat surfaces, and where additional drainage is needed such as fascia.

Weather seal should be applied around windows, doors, and other openings.

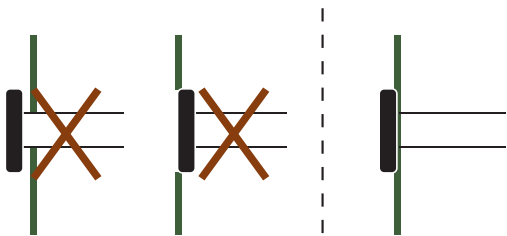

INCORRECT

CORRECT

When face nailing, ensure nails have a minimum penetration of 1-1/4" into the substrate, and the head must sit flush.

Always choose stainless steel ring shank nails with textured heads when installing your siding.

Bevel Siding Installation

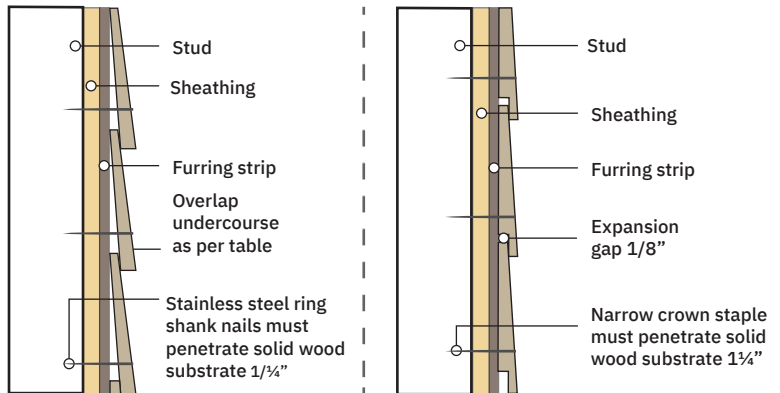

Fastener Method: Stainless steel ring shank faced nailed.

In horizontal applications, the grooved edge should face downwards. In vertical applications, start at one corner with a grooved edge toward the adjacent wall.

Nominal Width	Overlap (Inches)
4	1"
6	1"
8	1" to 1-1/8"
10	1" to 1-1/2"





INSTALLATION GUIDE

Tongue and Groove Siding Installation

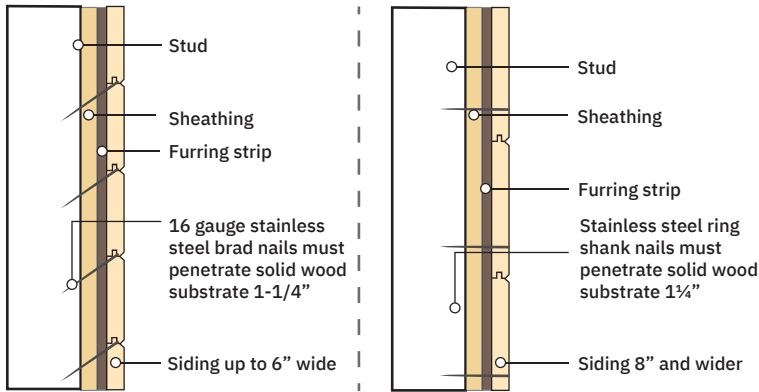

Channel Siding Installation

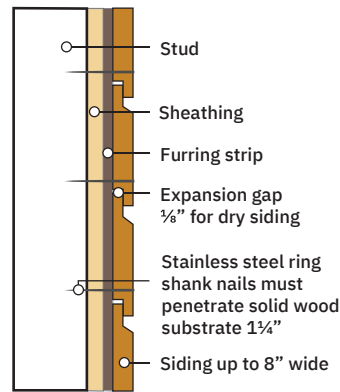

Fastener Method: Face nail with stainless steel ring shank fasteners that penetrate solid wood substrate 1-1/4".

T&G siding can be installed horizontally or vertically. In horizontal applications, start at the bottom and work up with grooved edges facing downwards.

In vertical applications, start at one corner with grooved edges facing the adjacent wall. Ensure the first board is installed plumb (grooved edge of the first board may have to be trimmed).

Fastener Method: Face nail with stainless steel ring shank fasteners that penetrate solid wood substrate 1-1/4".

In horizontal applications, install with the channel pointing up and allow a 1/8" expansion gap between pieces. Do not nail through overlaps.

For siding up to 6" wide, use one nail 1-1/4" from the lap.

For siding over 6" wide, use two nails per piece, keeping nails 2" to 3" apart.

For vertical application, siding should be nailed to horizontal blocking or furring strips.

Board and Batten

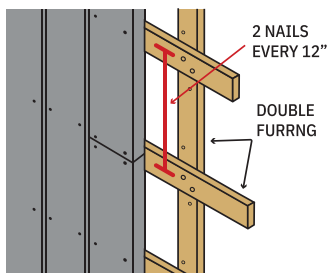
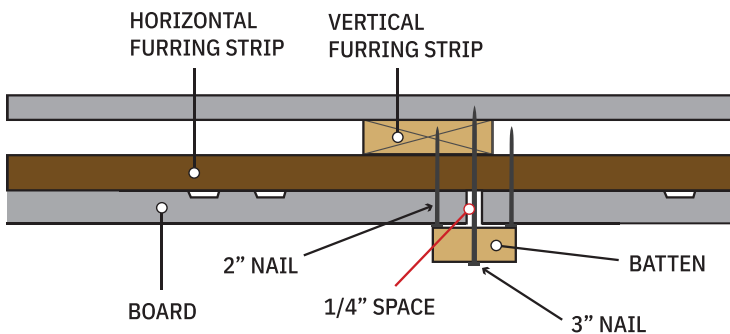

Fastener Method: Face nail with ring shank fasteners that penetrate solid wood 1-1/4".

Nominal 6" boards should be spaced 1/4"-1/2" apart with battens overlapping by at least 1/2". Increase batten overlap proportionately with wider boards.

Siding should be nailed to horizontal blocking lines or furring strips.

Boards up to 10" wide should be fixed with two nails, 1" to 1-1/2" from each side. Warranty does not cover anything over 10" board.

Additional Installation Considerations

Outside and Inside Corners

There are two ways to clad outside corners:

Mitered corners have a professional look but require carpentry skills to master, as they must fit tightly for the full depth of the miter.

Corner boards (usually nominal 1" or 5/4" thick) are applied to the furring strips, with the siding fitting tightly against the narrow edge of the boards. This allows for expansion and the use of a caulking bead. With inside corners, siding is usually butted against a 2x2 trim strip. Alternately, it can also be butted against adjoining walls with a trim strip installed to cover the joint.

Field Joints

When butt jointing siding:

- Cut ends at a 45-degree angle to form a scarf joint.
- Ensure joints meet on studs, blocking, or furring strips. Always coat any cut joints with touch up paint/stain.
- The nail should penetrate wood substrate at least 1-1/4".

This is an overview of installation methods for wood siding. Always follow specific installation requirements for your particular siding and adhere to local and national building codes. Proper installation is required to keep the warranty valid and should only be done by a professional with experience working with the particular siding product.

